



VERTICAL MAX-M HMB AC 110

Oven with top and lower heated cabinet



FEATURES

OUR CHARCOAL OVENS

The Mibrasa® oven is a closed grill designed and engineered in our workshops. Made from the best quality steel by expert hands, our grills are designed to satisfy even the most demanding chefs.

The technical specifications allow the user to accurately control the air flow through the grill, changing the intensity of the embers. This is an extremely efficient way of cooking and cuts down the amount of charcoal needed.

Mibrasa® charcoal ovens allow you to cook all types of foods retaining the natural flavors and bringing out a unique taste.

THE VERSATILITY OF MIBRASA® CHARCOAL OVENS

We have a wide range of high quality products and accessories allowing you to completely personalize your Mibrasa® charcoal oven, adapting it to your needs.

TECHNICAL INFORMATION

Item	HMB AC 110
Fire up time ¹	45 min
Cooking temperature	482 -662 °F / 250 - 350 °C
Initial charcoal load ¹	33 lb / 15 kg
Production*	220.5 lb / 100 kg/h
Charcoal load duration ²	8 h
Equivalent power*	6.7 hp / 5 kW
Exhaust rate	1883 cfm / 3200 m ³ /h
Net weight ³	1455 lb / 660 kg
Crated weight	1764 lb / 800 kg
Crate dimensions (WxDxH)	1) 43.3 x 43.3 x 53.2 in / 1100 x 1100 x 1350 mm 2) 43.3 x 43.3 x 80.7 in / 1100 x 1100 x 2050 mm

*Approximate data
1. Consult instruction manual
2. Will vary depending on quality of charcoal
3. Weight with accessories included

PAX PER SERVICE*



GRILL DIMENSION

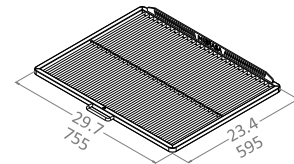

INCLUDED ACCESSORIES

- Grill [2] [GT110]
- Mibrasa tongs [TG]
- Ash shovel [PALA]
- Firebreak-dissipating filter [FB-DF]
- Poker [PK110]
- Grill brush [CEP]

RECOMMENDED ACCESSORIES

- Casters [WINOX]
- Removable grease collector [REG3/4]
- Consult catalogue for kitchenware and grillware

QUALITY GUARANTEE



Front view

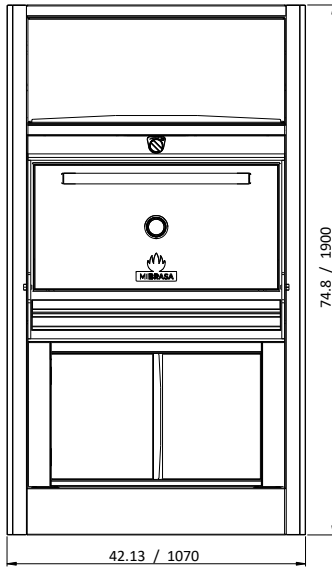

Side view

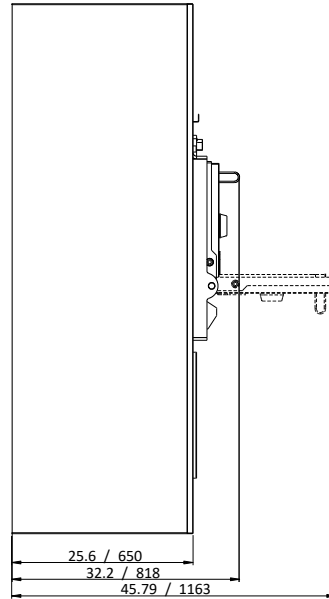

Option 1

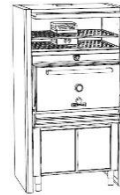

Option 2



Dimensions in in / mm

Revit drawings available on request at usa@mibrasa.com

Total height option 2: 84.3 in / 2141 mm

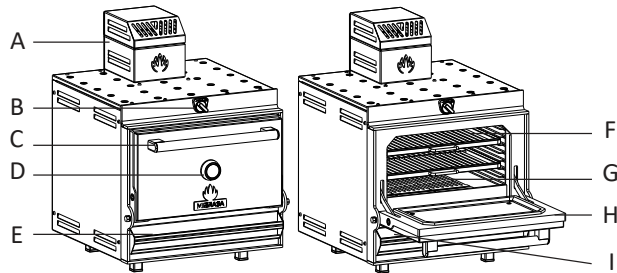

A	Firebreak-dissipating filter
B	Upper damper
C	Door handle
D	Thermometer
E	Lower damper/ash collector
F	Grills
G	Charcoal grids
H	Door
I	Grease collector

GASTORNORM CAPACITY

HEATING RACK (x2)

Compatible with Mibrasa GN.

Residual temperatures of the heating rack in the top cabinet approximately 302° F / 150° C, based on the oven working at 572° F / 300° C.

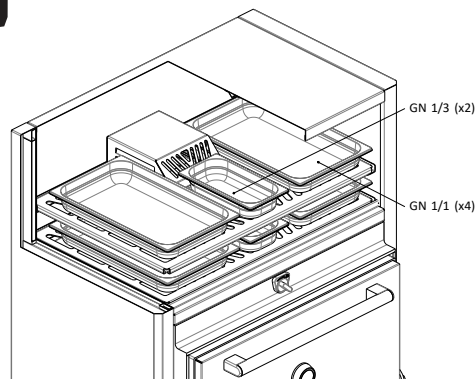

CUSTOMIZE

DOOR COLOR



BLACK



RED



YELLOW



STAINLESS STEEL



BLUE

EDITION



GOLD



BLACK



COPPER



TITANIUM



SILVER



WOOD*

The Edition finishes are applied to the logos, door handle and the thermometer casing.

*Only on the door handle (logos and thermometer casing in silver)

INSTALLATION GUIDELINES AND SAFETY STANDARDS

Recommended installation height	-
Clearances to construction / other appliances from oven	3 in / 76 mm
Clearances of flammable materials from oven	12 in / 300 mm
Clearance of workspace from front of the oven	44 in / 1100 mm



It is recommended to use a lifting device to lift the oven and place on the countertop/cabinet. Consult oven instruction manual for further information.

Specifications and design are subject to change without notice.